

INSTALLATION GUIDE

"Y" STRAINERS

WARNING

Read this Installation Manual PRIOR to installing this device. Noncompliance with safety and use information can result in serious personal injury, property damage, or damage to the device and may void the warranty. Keep this IOM for future reference.

Individuals performing removal and disassembly should be provided with suitable protection from possibly hazardous liquids.

INSTALLATION

1. Install blowdown valve (if provided) at blow-off connection. Also, for maximum efficiency, install a differential pressure gauge at inlet and outlet connections.
2. Y-Strainers must be positioned in the pipeline upstream of the equipment requiring protection. If the equipment requiring protection is a pump, the Y-Strainer must be placed on the suction side of the pump.
3. For ease of maintenance, the Y-Strainer should be located where the drain plug can be removed. Additionally, ensure the drain or blow-off is located at the lowest position when installed. If installed in the vertical position, the wye side of the strainer must be pointing downward.
4. Ensure there is ample space at the Y side of the strainer for screen removal.
5. Before placing the Y-Strainer into place, support the existing pipeline with pipe supports near the inlet and outlet connections.
6. Follow standard installation practices for threaded, sweat, press, or flanged connections, and place the Y-strainer into the pipeline. Ensure that the flow arrow on the body of the Y-Strainer is pointing in the direction of the media flow. For large or heavy strainers, appropriate material handling equipment must be used.

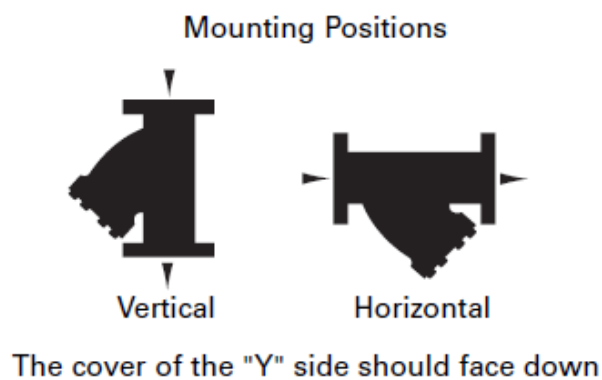

OPERATION

Once the installation and a pressure test has been successfully completed, start the system gradually, at start up as well as after shut down. This eliminates sudden shock to the strainer and other equipment in the line. This is extremely important for steam service.

MAINTENANCE

Y-Strainers are designed to require little maintenance. Regular maintenance involves:

- Blow-down cleaning.
- Timely cleaning or replacement of screen and gasket.
- Periodically checking for leaks.

During normal use, the screen will become clogged with debris, causing the differential pressure to increase. Once the differential pressure has increased to an unacceptable level, typically by 5 psi to 10 psi, it is time to clean or replace the screen. It is not advisable to let the differential pressure increase beyond 10 psi, as this may cause the screen to fail and possibly damage downstream equipment.

A convenient and safe way to determine when the screen needs to be replaced is to install pressure gauges on the inlet and outlet side of the strainer. The maximum acceptable pressure drop across the strainer will indicate when the screen needs to be replaced. Screen size and construction determine the maximum pressure drop a strainer screen can withstand.

Typical Threaded Y-Strainer

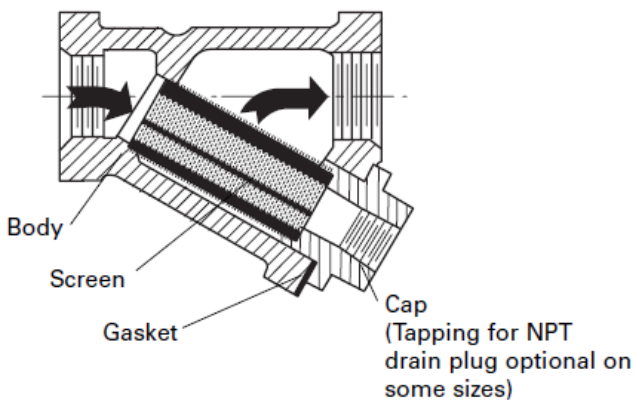

Typical Flanged End Y-Strainer

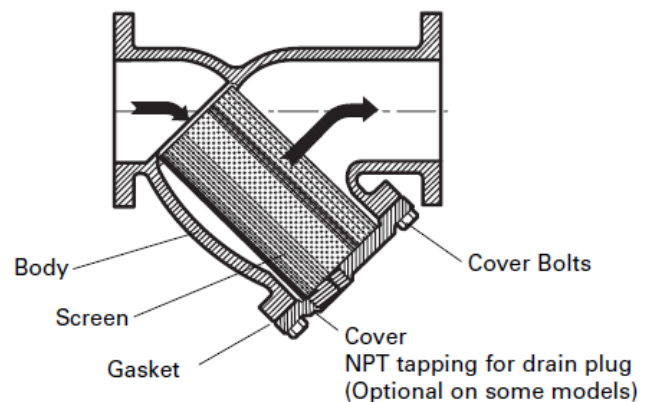

BLOW-DOWN CLEANING

To avoid shutting down the system, when possible, clean the screen when pressure differential is 5 to 10 psi. Clean the screen of debris by opening the blow-down valve. Keep valve open until all debris has been removed and pressure differential returns to normal range. Close the valve and resume normal operation. If pressure differential does not return to an acceptable level after blow-down cleaning, then the screen needs to be removed and cleaned or replaced.

Caution:

- The pressure inside the vessel must be reduced to atmospheric via suction or venting. Failure to do so may result in serious bodily injury.
- Before removing the cover of the Y-Strainer ensure that the media that is flowing in the pipeline is known and any special handling precautions are understood. Please review the Material Safety Data Sheet (MSDS) for that specific fluid.

SCREEN REMOVAL/CLEANING/REPLACEMENT:

1. Isolate the strainer by closing the inlet and outlet valve connections on either side of the Y-Strainer. Make sure valves are bubble tight.
2. Open blow-down valve or other vent to relieve pressure inside and drain fluid from the strainer.
3. Once pressure is relieved, remove the wye side cap or cover.
4. Remove screen and clean. Do not permit screen to dry as it will be difficult to remove debris after it has hardened. Avoid banging or hitting the screen to remove stubborn debris. For perforated screens, it is recommended to use high pressure water or air stream to clean the screen. This is not recommended for mesh or mesh lined screens as this may cause the mesh to tear. Solvent may be required if service is fuel, oil, or chemicals. Follow manufacturer's instructions when using solvent to clean the screen.
5. Inspect screen and cover gasket for damage. If either is damaged, replace. Always ensure there is a spare gasket and screen on hand prior to maintenance.
6. Remove any debris or sludge from within the strainer.
7. Replace cleaned or new screen into its original position, ensuring it is squarely positioned on the screen seat.
8. Replace cover gasket and cap or cover and tighten.
9. Close blow-down valve.

Typical Press-To-Connect Y-Strainer

