

Lead-Free* Class 125 Iron Body Check Valves

Twin Disc • Wafer Style • Bronze disc • Rubber seat • Spring Actuated

150 PSI/10.3 bar non-shock cold working pressure
Maximum temperature to 180°F/82°C

CERTIFIED LEAD-FREE* BY WQA TO NSF/ANSI 372 •
NSF/ANSI 61 CERTIFIED BY UL •
CONFORMS TO AWWA C518



C USA
COMPONENT LEAD-FREE



W-920-W-LF
Wafer



MATERIAL LIST — 14" thru 24"

PART	SPECIFICATION
1. Body	Cast Iron ASTM A126 Class B w/Buna-N (Nitrile) resilient seat molded to body
2. Disc	Aluminum Bronze ASTM B148 C95200
3. Torsion Spring	Stainless Steel ASTM A313 UNS S31600 or UNS S17700
4. Disc Thrust Bearing	Stainless Steel ASTM A240 UNS S31600
5. Stabilization Sphere	Buna-N
6. Hinge Pin Retainer	Steel
7. Stop Pin Retainer	Steel
8. Disc Stop Pin	Stainless Steel ASTM A276 UNS S31600
9. Disc Hing Pin	Stainless Steel ASTM A276 UNS S31600

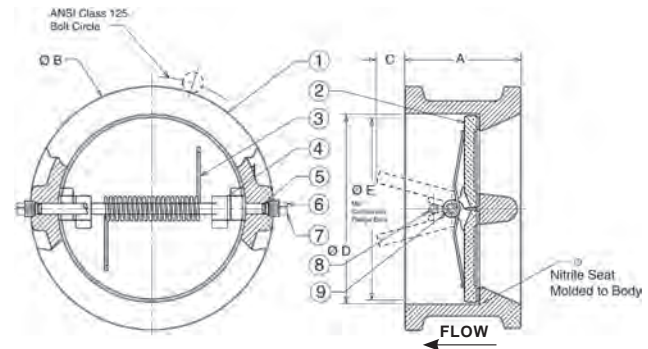

DIMENSIONS—WEIGHTS

Size	Dimensions										Weight		
	A		B		C		D		E		Lbs.	Kg.	
In.	mm.	In.	mm.	In.	mm.	In.	mm.	In.	mm.	In.	mm.		
14	350	7.25	184	17.75	451	3.25	83	14.38	365	12.50	318	187	85
16	400	7.50	191	20.25	514	4.50	114	16.38	416	15.00	381	270	122
18	450	8.00	203	21.63	549	5.38	137	18.38	467	17.00	432	350	150
20	500	8.38	213	23.88	606	6.38	162	20.25	514	19.00	483	424	192
24	600	8.75	222	28.25	718	8.50	216	24.25	616	23.00	584	589	267

NOTE: Twin Disc Check Valves can be installed horizontally or in the vertical position with flow up.

CAUTION: For horizontal flow applications, the valve must be installed with disc hinge pin in the vertical position, to insure proper operation.

- WARNING:**
1. Seat end of valve must be mated to a standard flat faced metal flange. Rubber flanges not acceptable.
 2. These are not to be used as steam valves.
 3. Valves are not to be used near a reciprocating air compressor.
 4. Install 5 pipe diameters minimum downstream from pump discharge or elbows to avoid flow turbulence. Flow straighteners may be required in extreme cases.

Note: On pump discharge, the preferred check valves are:

- inline, spring assisted, center-guided, lift checks
- spring assisted twin (double) disc
- swing design with lever and weight or lever and spring

Install 5 pipe diameters minimum downstream from pump discharge or changes in direction to avoid flow turbulence. Flow straighteners may be required in extreme cases.

WARNING: This product can expose you to chemicals including lead, which is known to the State of California to cause cancer and birth defects or other reproductive harm. For more information go to www.P65Warnings.ca.gov.

*Weighted average lead content ≤ 0.25%

Visit our website for the most current information.